

**MANUAL
AFC3
THREE RECEIVER
RACK MOUNT CHASSIS**

NOTE: The HDST jack is a 1/4 inch stereo jack.
Do not use a MONO headset plug as damage may
result.

DAYTON INDUSTRIAL CORPORATION
2237 Industrial Blvd
Sarasota, Florida 34234
Telephone: (941) 351-4454 Fax: (941) 351-6081
Visit our website at www.daytonindustrial.com

DAYTON INDUSTRIAL CORPORATION

MODEL AFC3 PROFESSIONAL THREE RECEIVER RACK MOUNT

DESIGNED ESPECIALLY FOR THE PROFESSIONAL MONITORING OR EAS MONITORING REQUIREMENTS, THE AFC3 PROVIDES THREE RECEIVERS IN A CONVENIENT 1 3/4 INCH RACK MOUNT PACKAGE.

AVAILABLE RECEIVERS INCLUDE WEATHER, FM, AM, AND PUBLIC SERVICE BAND (148 TO 175 MHz). THESE RECEIVERS ARE DESIGNED TO MEET PROFESSIONAL MONITORING AND EAS EQUIPMENT INPUT REQUIREMENTS.



THE GENERAL SPECIFICATIONS ARE:

A standard 1 3/4 inch high 19 inch rack mount chassis designed to contain up to three Dayton Industrial receivers. A minimum of one receiver is required.

The AFC3 contains a front panel AUDIO SELECTOR switch, mounted small speaker and HDST (headset) outputs controlled by the VOL control.

Also mounted on the front panel are LED indicators that indicate the presence of the CARRIER and MODULATION activity for each receiver.

An ALERT LED indicator and TEST/RESET switch is mounted on the front panel for those receivers that use tone detectors for sensing the ALERT mode, such as the weather and public service monitors.

The AFC3 rear panel contains the outputs for the chosen receivers. These outputs are the audio LINE (RCA unbalanced and DIN Balanced) outputs, SPKR (RCA) and RELAY (DIN) outputs. The power input (12VDC) is also located on the rear panel. Power is derived from a wall mounted converter.

Dayton Industrial Receivers:

We manufacture receivers that are designed to be components of the AFC3. These include the AF220 FM receiver, the AF310 AM receiver, the AF610 Weather (NOAA) receiver, AF850 Series Public Service Monitors and AF200A FM/SCA Receiver.

In general, these receivers are phase lock loop (P.L.L.) controlled with the frequency of operation selected using internal DIP or BCD switches. A continuous receiver LINE audio output is provided. A second output (SPKR) is also provided. In the Weather and Public Service monitors, the SPKR output audio is controlled automatically by tone detector circuits that monitor the receiver audio for the presence of specified alert tones. There is also a TEST and RESET switch for activating the SPKR audio and ALERT light manually.

All receivers have input power of 12 VDC and have automotive type regulators.

POWER:	115VAC to 12Vdc Power Converter (provided)
SIZE:	19" W x 9" D x 1 3/4" H
WEIGHT:	5.5 lbs. (w/o converter)

AFC3 CONTROLS/FEATURES :

- ? Three Receiver combined unit in a 1 3/4 inch rack,
- ? Front panel carrier and modulation LED indicators,
- ? Internal monitor speaker,
- ? Front panel HDST and VOL control,
- ? ALERT LED's and TEST/RESET switch,
- ? 10 volt automotive type internal regulator allows vehicle or **battery standby** operation,
- ? Designed for professional use.

DAYTON INDUSTRIAL CORPORATION

2237 Industrial Blvd., Sarasota, Florida 34234

Tel: (941) 351-4454 Fax: (941) 351-6081

E-Mail: daytonindustrial@aol.com

Please visit our website:

www.daytonindustrial.com

1.0 DESCRIPTION

The AFC3 is configured at the factory with one, two or three receivers as ordered. The receivers are described in the data attached to this manual. The receivers are labeled A,B,C for convenience. The front panel also has an identifier label that describes the receiver, such as “Weather”, FM 1, FM2, AM, etc.

2.0 POWER

Power is supplied to the AFC3 from a 12 Volt wall mounted power converter, capable of supplying 500mA minimum, (supplied with the AFC3).

The rear of the AFC3 has a 2.1 mm (center positive) power jack, labeled “12 VDC IN”, that matches the plug on the converter supplied. Other 12 VDC sources can be used to supply power to the AFC3. The internal regulators are 10 VDC automotive type allowing vehicle or standby battery operation.

The front panel has a “PWR”, red LED that lights when power is applied. If power is supplied to the AFC3, then power is applied to each internal receiver. The only way to disconnect the power from an internal receiver mounted in the AFC3 is by removing the AFC3 cover and removing the two pin power connector at the individual receiver board.

3.0 FRONT PANEL INDICATORS

3.1 CARRIER

There are three green LED indicators labeled, “CARRIER”. There is one indicator for each installed receiver. When power is applied, these indicators will light when a signal is received that exceeds a set threshold (usually -90 dbm) at the frequency of operation set by the receiver PLL circuit. Each receiver has switches that are set according to the manual to set the receiver operating frequency for that receiver. These switches are accessible only after removing the AFC3 chassis top cover. The CARRIER indicators are active at all times that power is applied to the AFC3 chassis.

3.2 MODULATION

There are three amber LED indicators labeled “MODULATION”. When the carrier indicator is lighted for a receiver, the associated MODULATION indicator will increase and decrease intensity with the modulation. These indicators are active whenever power is supplied to the AFC3 chassis and associated receiver.

If there is no carrier (carrier light “off”), the MODULATION indicator may be “on” continuously with noise. If there is an un-modulated carrier, the carrier light will be “on” and the MODULATION indicator will be “off”.

For those receivers that have the tone detector circuits, the MODULATION indicator will be “on”, indicating modulation, but the audio output may be “off”, depending on the state of the tone detector circuits (“on” or “off”).

3.3 AUDIO SELECT

The “AUDIO SELECT” switch mounted on the front panel is a four position switch which selects the audio signal from the internal receivers and applies it to the front panel speaker or HDST jack. The switch positions are labeled A,B,C, and OFF. Only one audio is selected at a time.

3.3.1 HDST DO NOT USE MONO PLUG — USE STEREO PLUG ONLY

This is a 1/4 inch standard jack for stereo headphones. All receivers are “MONO”, so the jack is wired to have the mono signal at both headphones. The HDST jack is wired so that the internal speaker is disconnected if the HDST jack is used.

3.3.2 VOLUME

The VOLUME control is mounted on the front panel. This controls the volume of the internal speaker and HDST jack, if connected.

3.3.2 SPEAKER

The AFC3 has a small speaker (16 Ohm) mounted to the front panel. The audio selected by the AUDIO SELECT switch is applied to the speaker. The speaker volume is controlled by the VOLUME control.

3.4 TONE DETECT

There are three red LED indicators labeled “TONE DETECT” on the front panel. These indicators are used when the installed receiver(s) have “alarm” or “mute” tone detectors. For example, the NOAA Weather Receiver contains tone detectors used to recognize “alert” tones which, when present, un-mute the receiver. If the alert tone is recognized, the audio is applied to the receiver output (rear panel), the AFC3 speaker, and the TONE DETECT light will light.

The tone detector circuits can be tested by selecting the receiver, A, B, or C using the AUDIO SELECT switch and using the TEST/RESET switch located on the front panel. For example, if the Weather receiver were installed as receiver B, select receiver B using the AUDIO SELECT switch, and then using the momentary switch “TEST/RESET”, contact the TEST position and the ALARM indicator will light and the Weather Receiver audio will be applied to the speaker or headset. To reset the tone detector circuits, contact the RESET momentary switch position. For receivers that do not have tone detector circuits, the TONE DETECT indicators do not operate.

3.4.1 TEST/RESET

This is a momentary contact switch used to test the tone detector circuits provided in the Weather and Public Service monitor receivers. When selected by the AUDIO SELECT switch, the TEST/RESET switch contacts will test and reset the receiver tone detector circuits. When the tone detector circuits are “on”, audio is applied to the speaker, the rear panel connector “SPKR” for the receiver, and the “TONE DETECT” indicator is lighted.

3.5 INDICATORS AND RECEIVERS

The operation of the indicators depends on the receivers installed in the AFC3.

RECEIVER	CARRIER	MODULATION	TONE DETECT	TEST/RESET
AF220 FM	Normal	Normal	None	None
AF310 AM	Normal	Normal	None	None
AF610 Weather	Normal	Normal	YES	YES/YES
AF810 Public Service Series	Normal	Normal	YES	YES/YES
AF200A FM/SCA	Select Main/SCA	Select Main/SCA	None	None

4.0 REAR PANEL CONNECTORS

4.1 POWER

The POWER input connector (a 2.1 mm (center positive) power connector) is located in the upper left hand corner of the rear panel and is labeled as 12 VDC IN. Power is supplied to the AFC3 from a 12 Volt wall mounted power converter, capable of supplying 500 mA minimum, (supplied with the AFC3).

Other 12 VDC sources can be used to supply power to the AFC3. The internal regulators are 10 VDC automotive type allowing vehicle or standby battery operation.

The front panel has a “PWR”, green LED that lights when power is applied. If power is supplied to the AFC3, then power is applied to each internal receiver. The only way to disconnect the power from an internal receiver mounted in the AFC3 is by removing the AFC3 cover and removing the two pin power connector at the individual receiver board.

4.2 RECEIVER CONNECTORS

The rear panel connectors depend on the type and number of receivers installed in the AFC3. The connectors for each receiver do follow a pattern, however, as indicated below:

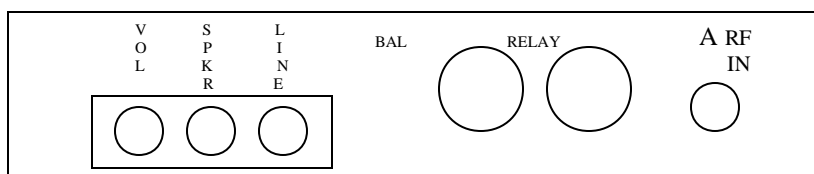

RF IN	“F” Connector	RF (Antenna) INPUT	
RELAY	5 pin DIN	See para 4.2.2	
BAL	5 pin DIN	See para 4.2.3	
LINE	RCA	1 VRMS, 600 Ohm , Audio	
SPKR	RCA	Receiver Audio Speaker Out (0.3 W, 16 Ohm)	
VOL	ADJUST	SPKR Volume Control	

4.2.1 RF IN

This connector is an “F” connector for connecting to the antenna input. The connector is labeled A,B, or C to correspond with the front panel receiver labels, A, B, or C and identifiers, FM1, FM2, AM, Weather, etc.

4.2.2 RELAY

For receivers that have carrier operated relays or alert tone relays a DIN connector is provided on the rear panel.

This DIN connector is a five pin DIN connector. The pin connections are:

PIN 1	Relay Armature Contact
PIN 2	Normally Closed Relay Contact
PIN 3	Normally Open Relay Contact
PIN 4	No Connection
PIN 5	No Connection

4.2.3 BAL

For receivers that have a balanced (600 Ohm) audio output, a DIN connector is provided on the rear panel.

This DIN connector is a five pin DIN connector. The pin connections are:

PIN 1	No Connection
PIN 2	No Connection
PIN 3	No Connection
PIN 4	L1 Balanced Line
PIN 5	L2 Balanced Line

4.2.4 LINE

This the receiver LINE output. The connector is unbalanced RCA for the audio or composite receiver output. This output may be muted in some receivers by the tone detect circuits or the carrier mute circuits.

4.2.5 SPKR

This is the receiver 8 Ohm speaker output. The speaker output volume is controlled by the rear panel VOL adjustment. For some receivers the SPKR output is muted by the tone alert circuits or carrier operated mute circuits.

4.2.6 VOL

The VOL control is a clockwise screwdriver adjust control for the receiver SPKR audio output. This control does not have any control of the LINE output or any of the front panel controls.

5.0 MAINTENANCE/REPAIR

The AFC3 chassis and installed receivers are all preset and tested at the factory. If any problems in operation are encountered, please contact the factory for assistance. Any receiver repair requires a certain amount of test equipment to insure proper alignment and operation.

There are no maintenance requirements for the AFC3 or receivers other than periodic cleaning as necessary. The AFC3 is designed for installation in an office or equipment room type environment.

6.0 ACCESS

In order to set the individual receiver operating frequency and make other operating settings for each receiver, it is necessary to remove the AFC3 top cover by removing the 14 screws holding the cover in place. Please refer to the attached manuals for each receiver type for instructions for the receiver settings.

7.0 INTERNAL CABLING

Each receiver is attached to the front panel circuit boards that hold the switches and indicator circuits by internal cables. These cable connections are outlined in the diagrams below.

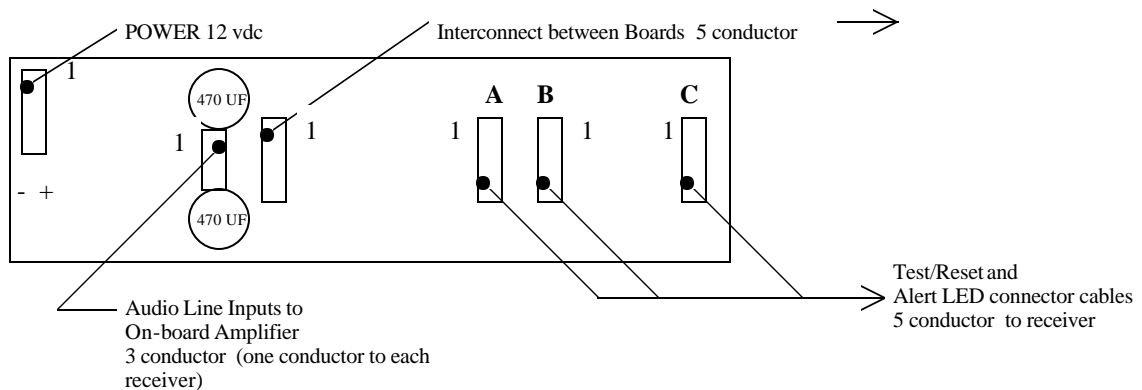

CIRCUIT BOARD FBAFC3A: holds the AUDIO SELECT 4 position switch, TEST/RESET switch, ALERT LED's and associated circuitry.

CIRCUIT BOARD FBAFC3B: holds the CARRIER and MODULATION indicator LED's and associated circuitry. This board has a 3 pin connector for connecting the "S" meter output from each receiver to the front panel board for the CARRIER indicators. The audio for the MODULATION indicators is provided by the 5 conductor interconnect cable that connects the two front panel boards.

CARRIER/MODULATION INDICATOR BOARD:

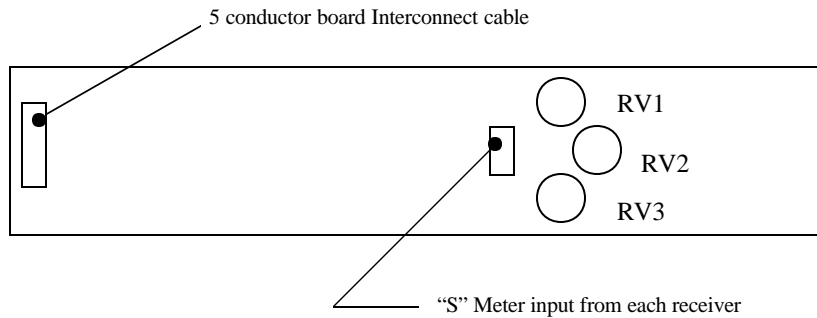

8.0 AFC3 ADJUSTMENTS

All adjustments are set at the factory for each individual receiver and also for the AFC3 circuit boards. The potentiometers labeled RV1, RV2 and RV3 on the CARRIER/MODULATION board (see above) set the level at which the receiver received field strength ("S" meter output) will light the appropriate CARRIER front panel LED.

There are no other adjustments in the AFC3 circuitry.

9.0 RECEIVER MANUALS ATTACHED

Receiver manuals pertinent to the configuration of your AFC3 is attached.

	AF200A FM/SCA
	AF220 FM
	AF310 AM
	AF610 Weather Receiver
	AF850 Series Public Service Band Monitors
	AF852 Low Band (30 to 50MHz)
	AF810 "High" Band (148 to 175 MHz)

10.0 TECHNICAL ASSISTANCE

For Questions or Assistance, contact:

Dayton Industrial Corporation

Attn: Engineering

2237 Industrial Blvd.

Sarasota, Florida 34234-3119 U.S.A.

Telephone: (941) 351-4454 (*mornings are best*)

Fax: (941) 351-6081

e-mail: engineering@daytonindustrial.com (*we will attempt to respond on a timely basis*)

web: www.daytonindustrial.com (*technical information is available on website*)