

MODEL AF225 FM RECEIVER/MONITOR OPERATION MANUAL

GENERAL:

The Model AF225 is a precision FM (mono) broadcast receiver designed for EAS or other monitoring purposes. The receiver is PLL (phase lock loop) controlled. The frequency of operation is selected using internal DIP switch combinations. A continuous LINE receiver output is provided as well as a SPKR audio output for driving an 8 Ohm speaker. The receiver is designed for the most demanding sensitivity, distortion, and signal to noise requirements. There are Carrier and Modulation indicators. Balanced audio output as well as Carrier Level Relay outputs are available as an option.



AF225 FM Receiver Front/Rear (with Relay Option)

The receiver circuit board has 10 VDC automotive style regulators. Input power is derived from wall mounted power converters (115 VAC to 12VDC) or other 12 VDC sources. The receiver is housed in a metal case or configured as one receiver in the AFC3 multiple receiver rack mount chassis.

SPECIFICATIONS:

Tuning Range:	88 to 108 MHz, selected by internal DIP switch.
Antenna Input:	"F" connector, 75 Ohm
Sensitivity:	1.0 microvolt, 12 dB SINAD 3.0 microvolt limiting
Frequency Response:	20HZ to 15KHz (-3dB)
Distortion:	0.25% THD at 100% Mod
Maximum s/n:	60 dB
Line Output:	1.0 V rms, 600 Ohms
SPKR Output:	0.5 Watt into 8 Ohms
AM Rejection:	50dB
Intermodulation:	5 mV (73dB) Rejection

POWER REQUIREMENTS:

115 VAC, 20 Watts; 12VDC, 300 mA (wall converter provided)

CONTROLS:

VOL Control:	Rear Panel mount Screwdriver adjust
Carrier Level Relay:	Internal adjust (RV2)
Line Level Adjust:	Internal Adjust (RV3)

INDICATORS:

Carrier:	Front Panel mount LED
Modulation:	Front Panel mount LED
Power:	Front Panel mount LED

SIZE:

Metal Case Size:	6.0"W x 8"D x 1 3/4"H Weight 1.5 lbs
------------------	---

OPTIONS AVAILABLE:

Option -MF 19" front panel rack mount (1 3/4")
 Option -B Balanced LINE output via DIN connector
 Option -R Carrier operated Relay via DIN connector
 AF225 can be selected as one of the receivers in the AFC3 package (options B & R are standard in the AFC3).

DAYTON INDUSTRIAL CORPORATION

2237 Industrial Blvd

Sarasota, Florida 34234

Telephone: (941) 351-4454 Fax: (941) 351-6081

Visit our website at www.daytonindustrial.com

SETTING THE FREQUENCY OF OPERATION:

The first item to be performed is to set the receiver frequency of operation. The receiver is a PLL design, the frequency is set by a series of switches, arranged as internal DIP switches, marked SW1 and SW2. Access to the switches is by removing the top cover of the receiver. Locate SW1 and SW2 on the circuit board (refer to parts layout diagram on page 4). The switches are marked indicating the “on” position. The “on” position for a switch is the logical “1”, and the “off” position is the logical “0” for the receiver microcontroller. **Please note that SW2 positions R1 and R2 are always to be in the “0” or “off” position.**

The frequency of operation is set by the positions of switches D0, D1,...through...D11, (D12,D13 are always Off). Note that the switch “on” position is always the position towards the microcontroller, IC10. Table 1.0 lists the switch position for each switch corresponding to the desired frequency of operation. Set the switches according to Table 1.0 for the desired operating frequency.

CONNECTORS/CONTROLS (REAR):

After setting the frequency, the next item is to make connections at the receiver rear panel. The connectors are shown in Figure 1.0 for the individual unit chassis. Similar connections are made on the rear panel of the AFC3 if the AF225 is one receiver of the AFC3 chassis.

FIGURE 1.0

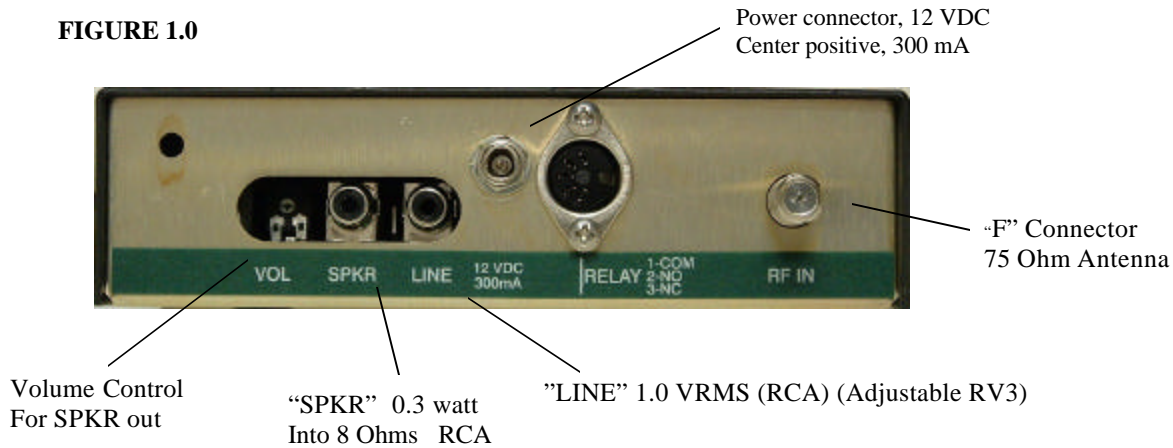

AF225 REAR PANEL (Individual Unit Chassis or as Mounted in the AFC3 chassis) (relay option installed)

RF (88 - 108 MHz), RF IN: The RF connector is an “F” connector. The input impedance is 75 Ohms. The antenna connection should be coaxial cable to reduce interference.

LINE Output: Receiver composite output from the audio to some 110KHz. An RCA connector (unbalanced) is provided. Note: The LINE output level is adjustable using the potentiometer on the circuit board (RV3).

SPKR Output: Audio output capable of driving an 8 Ohm speaker, 0.3 watt. RCA connector.

VOL: A screwdriver volume control for the SPKR powered audio output.

POWER: In the individual units (AF225), this is a center positive connector for 12 VDC, 300mA, input power. The input power is normally derived from a wall converter (115 VAC to 12 VDC) which is supplied, but other +12Vdc sources can be used. In the AFC3 chassis mounted unit, the power is derived from the AFC3 chassis.

FIGURE 1.0

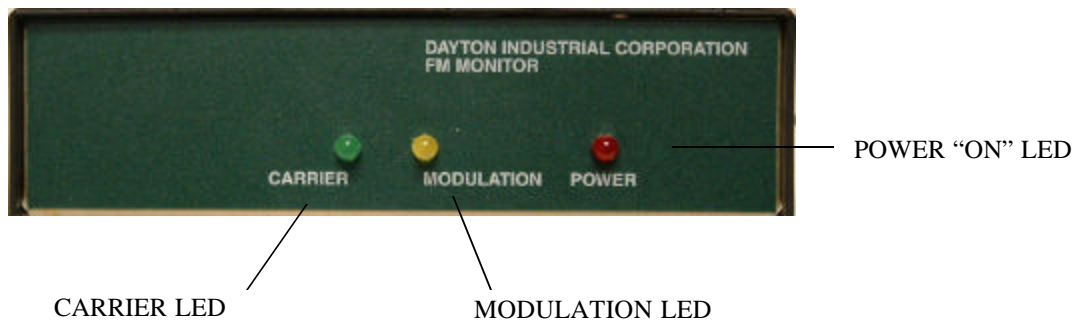

AF225 FRONT PANEL (Individual unit or Front Panel Controls of the AFC3)

FRONT PANEL INDICATORS :

POWER: Indicator; Red LED that lights as long as power is applied. In the AFC3 chassis power is derived from the AFC3.

CARRIER: Indicator; Green LED that lights when the main carrier is present and above a preset received level (usually -90 dBm).

MODULATION: Indicator; When a “CARRIER indicator is lighted, this Amber LED will increase and decrease in intensity with the modulation audio. If there is no carrier (CARRIER light “off”), the MODULATION indicator may be “on” continuously with noise. If there is an un-modulated carrier present, then the CARRIER light will be “on” and the MODULATION light will be “off”.

OPERATION: Operation is straight forward. Connections are made to the appropriate connectors and power is applied. The POWER indicator should be bright. The LINE and SPKR outputs will be active. The SPKR output volume is controlled by the rear panel VOL screwdriver adjust control. If a carrier is present, the CARRIER light will be bright and the MODULATION indicator intensity will fluctuate with the audio that is present.

TROUBLESHOOTING: No attempt to service or adjust the receiver should be made. If power is applied, but the receiver does not operate, and it is a new unit, then please return it to the factory for an exchange. If it should fail after some time in service, check the 115 VAC source to make sure power has not been disconnected. If the 115 VAC is verified, try replacing the 115VAC to 12 VDC power converter. If the receiver still fails to operate, the failure must be internal to the receiver and the receiver should be returned to the factory for service.

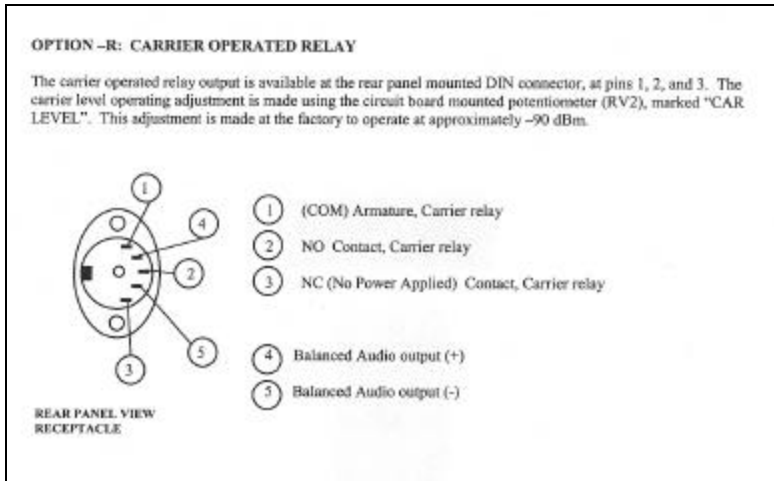

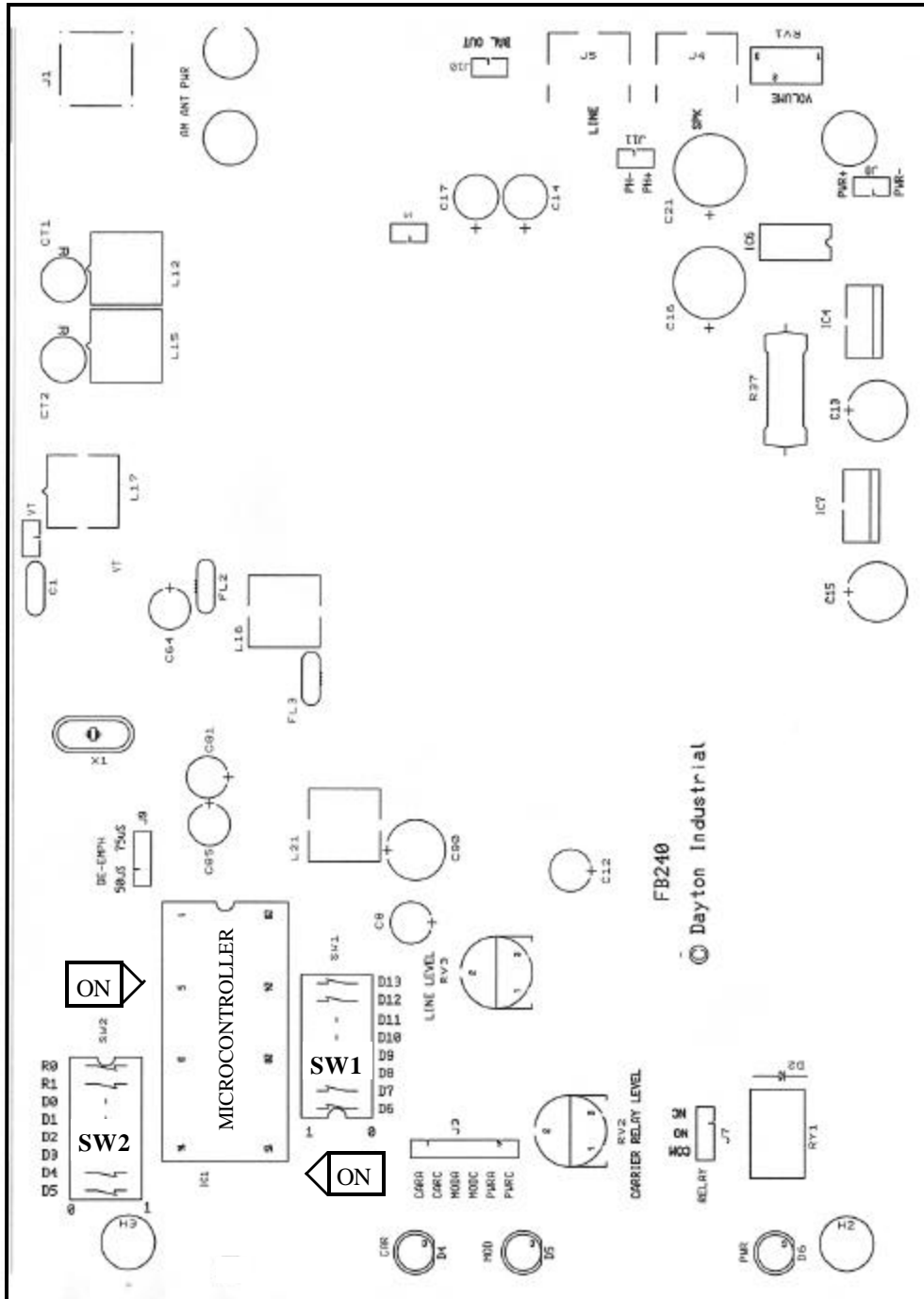

Model AF225 FM Receiver Printed Circuit Board Parts layout showing position of the DIP switch used to set the operating frequency.

DAYTON INDUSTRIAL CORPORATION
 2237 Industrial Blvd, Sarasota, Florida 34234
 Telephone: (941) 351-4454 Fax: (941) 351-6081
 Visit our website at www.daytonindustrial.com

DIP Switch Settings for FM Receiver Operation (LC72131)													DIP Switch Settings for FM Receiver													DIP Switch Settings for FM Receiver Operation																					
NOTE: R0=0 and R1=0													Note: R0=0 and R1=0													Note: R0=0 and R1=0																					
Frequency	D0	D1	D2	D3	D4	D5	D6	D7	D8	D9	D10	D11	Frequency	D0	D1	D2	D3	D4	D5	D6	D7	D8	D9	D10	D11	Frequency	D0	D1	D2	D3	D4	D5	D6	D7	D8	D9	D10	D11									
87.5	1	1	0	1	0	1	1	1	1	1	0	0	0	94.3	0	1	1	1	0	0	0	0	0	1	0	0	101.5	1	0	0	0	1	1	0	0	1	1	0	0	1	0	0	1	0	0		
87.7	0	0	1	1	0	1	1	1	1	1	0	0	0	94.7	1	1	1	1	0	0	0	0	0	0	1	0	0	101.7	0	1	0	0	1	1	0	0	1	1	0	0	1	0	0	1	0	0	
87.9	1	0	1	1	0	1	1	1	1	1	0	0	0	94.9	0	0	0	1	0	0	0	0	0	0	1	0	0	101.9	1	1	0	0	1	1	0	0	1	1	0	0	1	0	0	1	0	0	
88.1	0	1	1	1	0	1	1	1	1	1	0	0	0	95.1	0	0	0	1	0	0	0	0	0	0	1	0	0	102.1	0	1	0	1	0	1	1	0	0	1	1	0	0	1	0	0	1	0	0
88.3	1	1	1	1	0	1	1	1	1	1	0	0	0	95.3	0	1	0	0	1	0	0	0	0	0	1	0	0	102.3	1	0	1	0	1	1	0	0	1	1	0	0	1	0	0	1	0	0	
88.5	0	0	0	1	1	1	1	1	1	1	0	0	0	95.5	1	1	0	0	1	0	0	0	0	0	1	0	0	102.5	0	1	1	0	1	1	0	0	1	1	0	0	1	0	0	1	0	0	
88.7	1	0	0	1	1	1	1	1	1	1	0	0	0	95.7	0	1	0	1	0	0	0	0	0	0	1	0	0	102.7	1	1	0	1	1	0	0	1	1	0	0	1	0	0	1	0	0		
88.9	0	1	0	0	1	1	1	1	1	1	0	0	0	95.9	1	0	1	0	1	0	0	0	0	0	1	0	0	102.9	0	0	0	1	1	0	0	1	1	0	0	1	0	0	1	0	0		
89.1	1	1	0	0	1	1	1	1	1	1	0	0	0	96.1	0	1	1	0	1	0	0	0	0	0	1	0	0	103.1	1	0	0	1	1	0	0	1	1	0	0	1	0	0	1	0	0		
89.3	0	0	1	1	1	1	1	1	1	1	0	0	0	96.3	1	1	1	0	1	0	0	0	0	0	1	0	0	103.3	0	1	0	1	1	1	0	0	1	1	0	0	1	0	0	1	0	0	
89.5	1	0	1	0	1	1	1	1	1	1	0	0	0	96.5	0	0	1	1	0	0	0	0	0	0	1	0	0	103.5	1	1	0	1	1	1	0	0	1	1	0	0	1	0	0	1	0	0	
89.7	0	1	1	0	1	1	1	1	1	1	0	0	0	96.7	1	0	0	1	1	0	0	0	0	0	1	0	0	103.7	0	0	1	1	1	1	0	0	1	1	0	0	1	0	0	1	0	0	
89.9	1	1	0	1	1	1	1	1	1	1	0	0	0	96.9	0	1	0	1	1	0	0	0	0	0	1	0	0	103.9	1	0	1	1	1	1	0	0	1	1	0	0	1	0	0	1	0	0	
90.1	0	0	1	1	1	1	1	1	1	1	0	0	0	97.1	1	1	0	1	1	0	0	0	0	0	1	0	0	104.1	0	1	1	1	1	1	0	0	1	1	0	0	1	0	0	1	0	0	
90.3	1	0	0	1	1	1	1	1	1	1	0	0	0	97.3	0	0	1	1	1	0	0	0	0	0	1	0	0	104.3	1	1	1	1	1	1	0	0	1	1	0	0	1	0	0	1	0	0	
90.5	0	1	0	1	1	1	1	1	1	1	0	0	0	97.5	1	0	1	1	1	0	0	0	0	0	1	0	0	104.5	0	0	0	0	0	0	0	0	1	1	0	0	1	0	0	1	0	0	
90.7	1	1	0	1	1	1	1	1	1	1	0	0	0	97.7	0	1	1	1	1	0	0	0	0	0	1	0	0	104.7	1	0	0	0	0	0	0	0	1	1	0	0	1	0	0	1	0	0	
90.9	0	0	1	1	1	1	1	1	1	1	0	0	0	97.9	1	1	1	1	1	0	0	0	0	0	1	0	0	104.9	0	1	0	0	0	0	0	0	1	1	0	0	1	0	0	1	0	0	
91.1	1	0	1	1	1	1	1	1	1	1	0	0	0	98.1	0	0	0	0	1	0	0	0	0	0	1	0	0	105.1	1	1	0	0	0	0	0	0	1	1	0	0	1	0	0	1	0	0	
91.3	0	1	1	1	1	1	1	1	1	1	0	0	0	98.3	1	0	0	0	1	0	0	0	0	0	1	0	0	105.3	0	0	1	0	0	0	0	0	1	1	0	0	1	0	0	1	0	0	
91.5	1	1	1	1	1	1	1	1	1	1	0	0	0	98.5	0	1	0	0	1	0	0	0	0	0	1	0	0	105.5	1	0	1	0	0	0	0	0	1	1	0	0	1	0	0	1	0	0	
91.7	0	0	0	0	0	0	0	0	0	0	0	0	0	98.7	1	1	0	0	1	0	0	0	0	0	1	0	0	105.7	0	1	1	0	0	0	0	0	1	1	0	0	1	0	0	1	0	0	
91.9	1	0	0	0	0	0	0	0	0	0	0	0	0	98.9	0	0	1	0	0	1	0	0	0	0	1	0	0	105.9	1	1	0	0	0	0	0	0	1	1	0	0	1	0	0	1	0	0	
92.1	0	1	0	0	0	0	0	0	0	0	0	0	0	99.1	1	0	1	0	0	1	0	0	0	0	1	0	0	106.1	0	0	0	1	0	0	0	0	1	1	0	0	1	0	0	1	0	0	
92.3	1	1	0	0	0	0	0	0	0	0	0	0	0	99.3	0	1	1	0	0	1	0	0	0	0	1	0	0	106.3	1	0	0	1	0	0	0	0	1	1	0	0	1	0	0	1	0	0	
92.5	0	0	1	0	0	0	0	0	0	0	0	0	0	99.5	1	1	1	0	0	1	0	0	0	0	1	0	0	106.5	0	1	0	1	0	0	0	0	1	1	0	0	1	0	0	1	0	0	
92.7	1	0	1	0	0	0	0	0	0	0	0	0	0	99.7	0	0	0	1	0	1	0	0	0	0	1	0	0	106.7	1	1	0	1	0	0	0	0	1	1	0	0	1	0	0	1	0	0	
92.9	0	1	1	0	0	0	0	0	0	0	0	0	0	99.9	1	0	0	1	0	1	0	0	0	0	1	0	0	106.9	0	0	1	1	0	0	0	0	1	1	0	0	1	0	0	1	0	0	
93.1	1	1	1	0	0	0	0	0	0	0	0	0	0	100.1	0	1	0	1	0	1	0	0	0	0	1	0	0	107.1	1	0	1	1	0	0	0	0	1	1	0	0	1	0	0	1	0	0	
93.3	0	0	0	1	0	0	0	0	0	0	0	0	0	100.3	1	1	0	1	0	1	0	0	0	0	1	0	0	107.3	0	1	1	1	0	0	0	0	1	1	0	0	1	0	0	1	0	0	
93.5	1	0	0	1	0	0	0	0	0	0	0	0	0	100.5	0	0	1	1	0	1	0	0	0	0	1	0	0	107.5	1	1	1	0	0	0	0	0	1	1	0	0	1	0	0	1	0	0	
93.7	0	1	0	1	0	0	0	0	0	0	0	0	0	100.7	1	0	1	1	0	1	0	0	0	0	1	0	0	107.7	0	0	0	0	1	0	0	0	1	1	0	0	1	0	0	1	0	0	
93.9	1	1	0	1	0	0	0	0	0	0	0	0	0	100.9	0	1	1	1	0	1	0	0	0	0	1	0	0	107.9	1	0	0	0	1	0	0	0	1	1	0	0	1	0	0	1	0	0	
94.1	0	0	1	1	0	0	0	0	0	0	0	0	0	101.1	1	1	1	1	0	1	0	0	0	0	1	0	0	108.1	0	1	0	0	1	0	0	0	1	1	0	0	1	0	0	1	0	0	
94.3	1	0	1	1	0	0	0	0	0	0	0	0	0	101.3	0	0	0	0	1	1	0	0	0	0	1	0	0	108.3	0	1	0	0	1	0	0	0	1	1	0	0	1	0	0	1	0	0	

D12 and D13 are always OFF

AF225 FM Receiver Frequency Switch Settings